



ROEMHELD
HILMA ■ STARK

Contact:

Andreas Reich
Hilma-Roemheld GmbH
Head of QDC/ QMC
Tel.: +49 2739 4037 162
Email: a.reich@hilma.de

F. Stephan Auch
auchkomm Unternehmenskommunikation
Tel.: +49 911 27 47 100
Email: fsa@auchkomm.de

Römhheld GmbH
Friedrichshütte
Römhheldstraße 1-5
35321 Laubach
Germany
Tel.: +49 (0) 6405 / 89-0
Fax: +49 (0) 6405 / 89-211
E-mail: info@roemheld.de
www.roemheld.com

Press Release 4/2024

- **ROEMHELD redesigns sturdy and safe arch clamps for presses, injection moulding, rubber and forging applications**
- **For the harshest applications, as well as dirty, hot environments up to 250° C**

Laubach, August 13, 2024 — ROEMHELD has improved its tried and tested arch clamps. The extremely sturdy, double-acting hydraulic component is used to clamp dies with straight clamping edges. As experts in clamping technology, ROEMHELD has now simplified and accelerated production processes while maintaining the same superior quality. Customers will also benefit from a slightly lower price.

The clamping element is suitable for dirty, hot environments on press beds and rams in sheet metal forming, die casting, rubber and forging applications. A special, long-lasting corrosion-resistant coating ensures excellent sliding properties. As a result, the bolt releases effortlessly even under the most demanding use.

High operating and process reliability

The component is named after the arch-shaped clamping bolt, which clamps the die when it is placed on the straight clamping edge. During this movement, the horizontally acting force is deflected and hits the clamping surface almost vertically.

The arch clamp is available in seven different versions. They are each available in versions with or without position monitoring for particularly high process reliability. This informs the operator as to whether the bolt clamps or unclamps the die and whether the clamping position is overrun. Models with position control are available for temperatures up to 100° C. Without this option, the upper limit is 250° C.

For special applications, it is also possible to use position monitoring with sequence valve control up to 250° C.

An integrated mechanical locking bolt holds the upper die reliably, even in the event of a pressure loss, so that it cannot fall. The clamping and unclamping pressures are 200 bar in each case, the



clamping force varies between 30 and 450 kN depending on the model, and the maximum permissible process force is 620 kN.

About the ROEMHELD Group

From medical engineering and mechanical engineering to the automotive, aerospace and agricultural industries or the production of smartphone cases: technologies and products of the companies in the ROEMHELD Group have been used to manufacture numerous industrial commodities and goods for end users for more than 80 years.

The ever-growing range of more than 25,000 catalogue items includes innovative and intelligent solutions for manual and automated clamping and set-up of dies, workpieces, fixtures and pallets as well as for handling and assembly. They are used by numerous industrial companies worldwide, especially in machining, forming technology, plastics processing and 3D printing.

The focus is always on efficiency and productivity — through minimum set-up times, fast manufacturing and high flexibility.

Innovation through tradition: ROEMHELD was established in 1707 with a foundry in Friedrichshütte, which still belongs to the ROEMHELD Group today and counts as one of Germany's oldest active industrial businesses.

Three members belong to the owner-managed group of companies. Römheld GmbH Friedrichshütte, Laubach, Germany, is responsible for workholding elements, assembly and handling technology as well as die clamping and change technology. Zero point clamping systems, machine vices and tower workholding systems are produced by STARK Spannsysteme GmbH, Rankweil, Austria. Technical consulting and development of machine vices, tower workholding systems as well as die clamping and changing technology takes place at Hilma-Römheld GmbH in Wilnsdorf, Germany.

The Group employs around 530 people and is represented by service and sales companies in over 50 countries. It achieves an annual turnover of more than 90 million euros.



Photo:

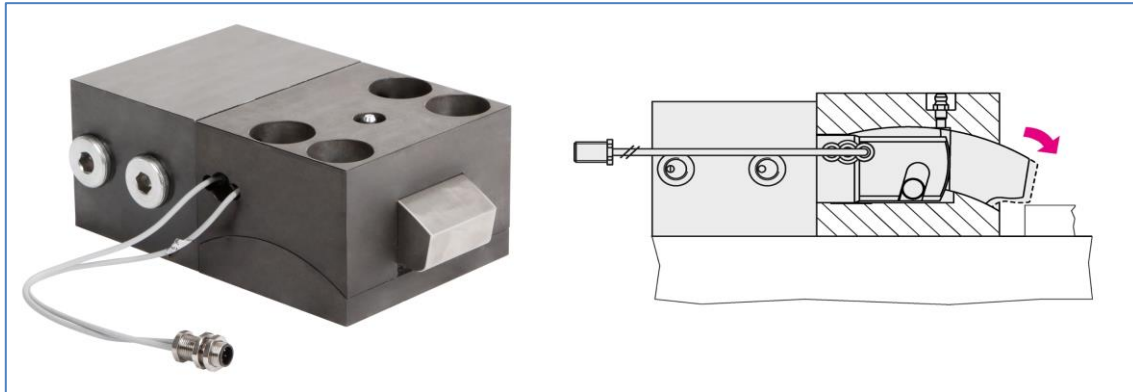

ROEMHELD has improved its tried and tested arch clamps (image: ROEMHELD).

Download the press release as a Word document and the images in print quality here:

https://www.auchkomm.com/aktuellepresstexte#PI_577

Author's copy requested:

auchkomm Unternehmenskommunikation, F. Stephan Auch, Hochstraße 11, D-90429 Nuremberg,
fsa@auchkomm.de, www.auchkomm.de